



ENTSOOG a New Player in the Gas Arena

Vittorio Musazzi
ENTSOOG General Manager

Gie Annual Conference
Vienna, 25 June 2010

Who is ENTSOG?

- European Network for Transmission System Operators for Gas
- Founded by European Gas Transmission System Operators (TSOs) Dec 1, 2009
 - ➔ Two years ahead of formal implementation under the Third European Legislative Energy Package
- 32 Members from 22 countries

ENTSOG

Articles, Rules completed Oct 2009

Despatched to Commission, ERGEG

Available on ENTSOG Website

GTE+ transferred into ENTSOG on 1 Dec 2009

Brussels, 83, Rue Ducale

GTE remains active as a column of GIE

ENTSOG's Mission & Vision

... by fulfilling its tasks under the 3rd Package and offering a platform for a truly European TSO co-operation, ENTSOG shall:

- enable easy grid access
- facilitate cross-border gas flows
- promote the integration of the European energy market
- be a fair partner to all stakeholders

ENTSOG Organization

General Assembly



Board



European network
of transmission system operators
for gas

32 Transmission System Operators
22 countries



Board representation



11 countries
12 members

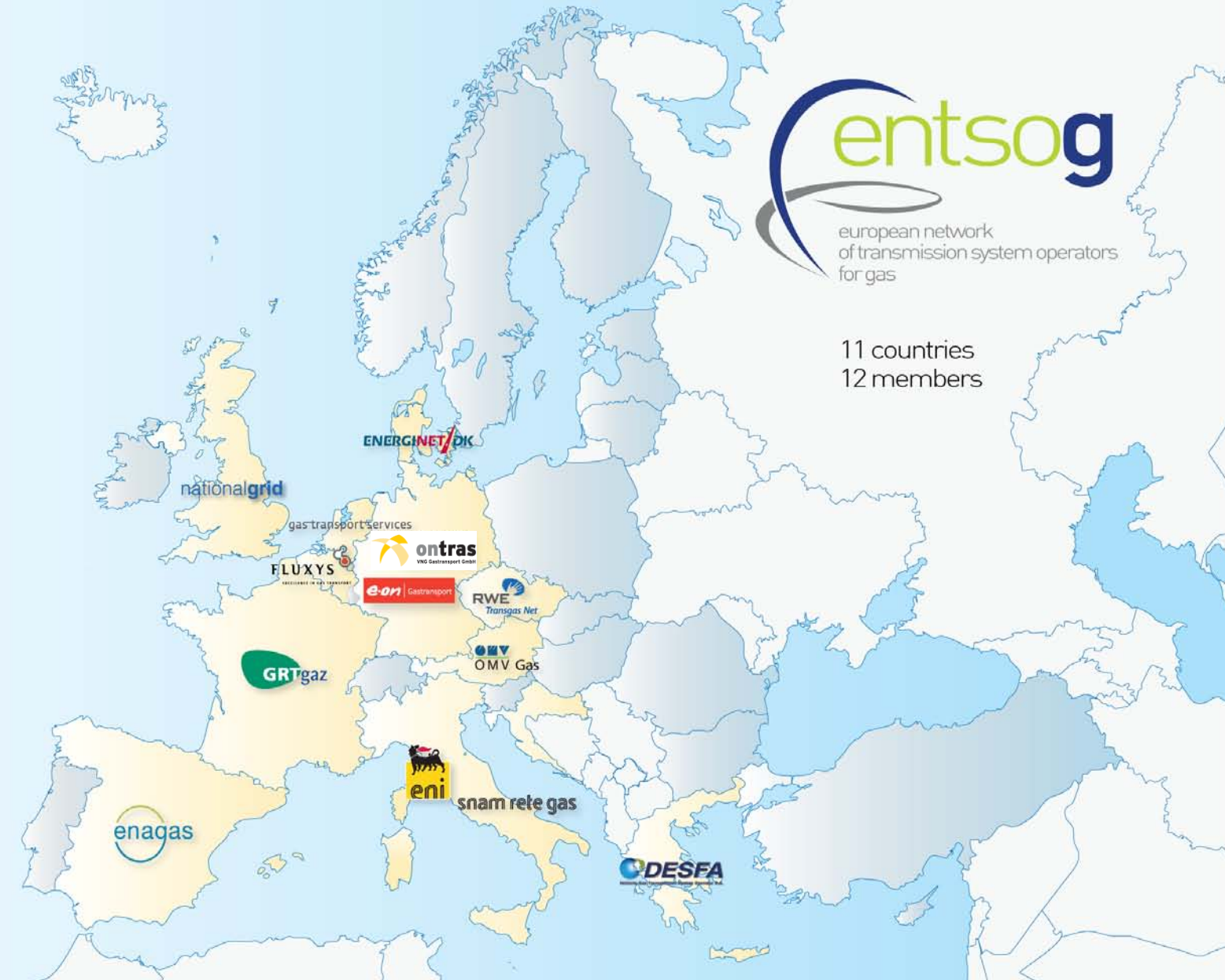

ENTSOG Organization

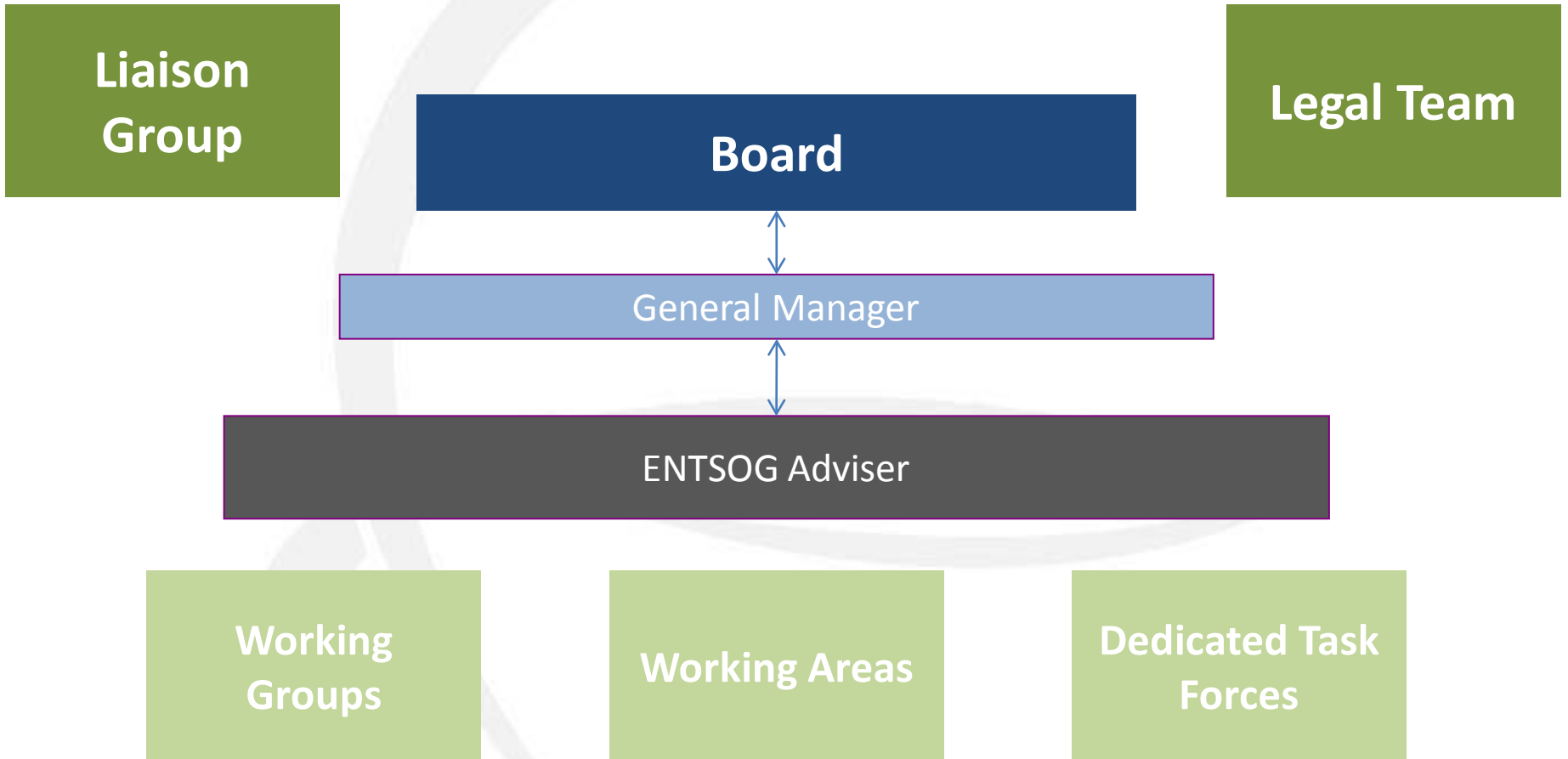

TSOs' Commitment to ENTSOG

Brussels based

Small Brussels team working with extensive inputs from member companies

Brussels team

Member's staff

ENTSOG Members'

Working Group participants

ENTSOG Organization - Advisers



A. Cirlicova
Investment and Transparency



N. Sisman
Balancing, Tariff
Regional Co-operation



F. Roessler
Capacity



R. Van der Meer
Balancing



P. Panousos
Transparency and
Interoperability



O. Lebois
Investment and Capacity

ENTSOG Activity Areas 2010

- Investment
- Transparency
- Balancing
- Interoperability
- Capacity Pilot Network Code development
- Tariff
- Regional Co-operation
- Answer to EC/Regulator questionnaire or studies
- Organization set up



ENTSOGE Activity Areas 2010

- Investment area
 - European Ten Year Network Development Plan
 - European Summer and Winter Outlooks
 - Co-operation with EC for the next Infrastructure package



ENTSOG Activity Areas 2010

➤ Transparency area

- Coordination of Members towards implementation of publication requirement according to Third package
- Enhancement of quality of data available in ENTSOG's Platform
- Development of new features on Platform to improve data utilization by users

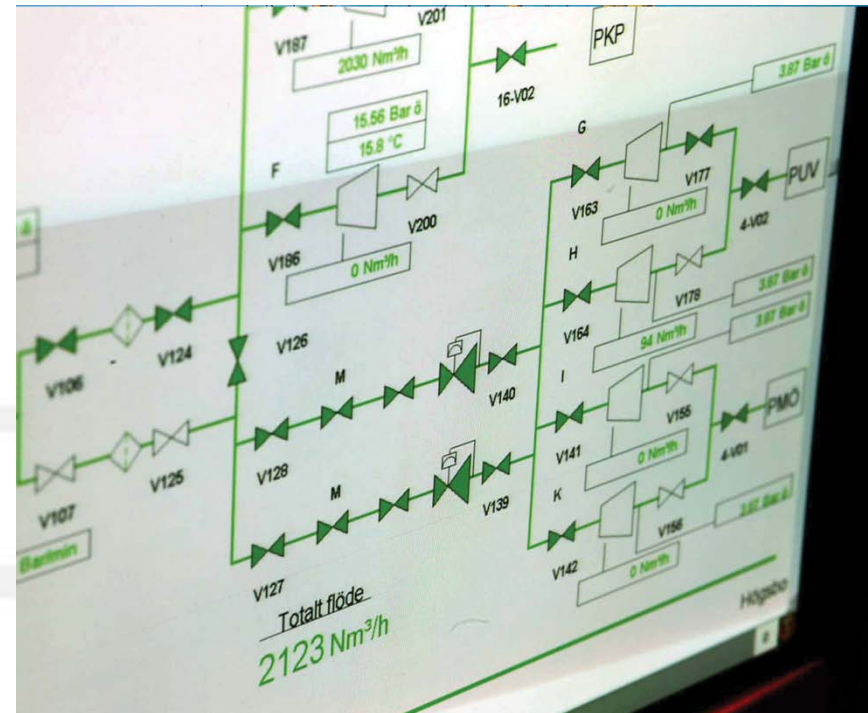

ENTSOG Activity Areas 2010

➤ Balancing area

- Market based balancing report
- Genuine physical needs assessment
- Extensive stakeholder and ERGEG engagement
- ERGEG's framework guideline consultation process



ENTSOG Activity Areas 2010

➤ Interoperability area

- Development of a common network operational tool
- Cooperation towards the definition of quality parameters to ensure gas interchangeability
- Adoption of common set of recommended Units
- Development of a common approach towards IT communication and data formats



ENTSO-G Activity Areas 2010

➤ Capacity area

- Support to ERGEG to development of the framework Guideline for Pilot Network Code
- Meetings with Stakeholder to inform them on the ongoing activities and to share with them a common approach to network code development



Roles and Participation

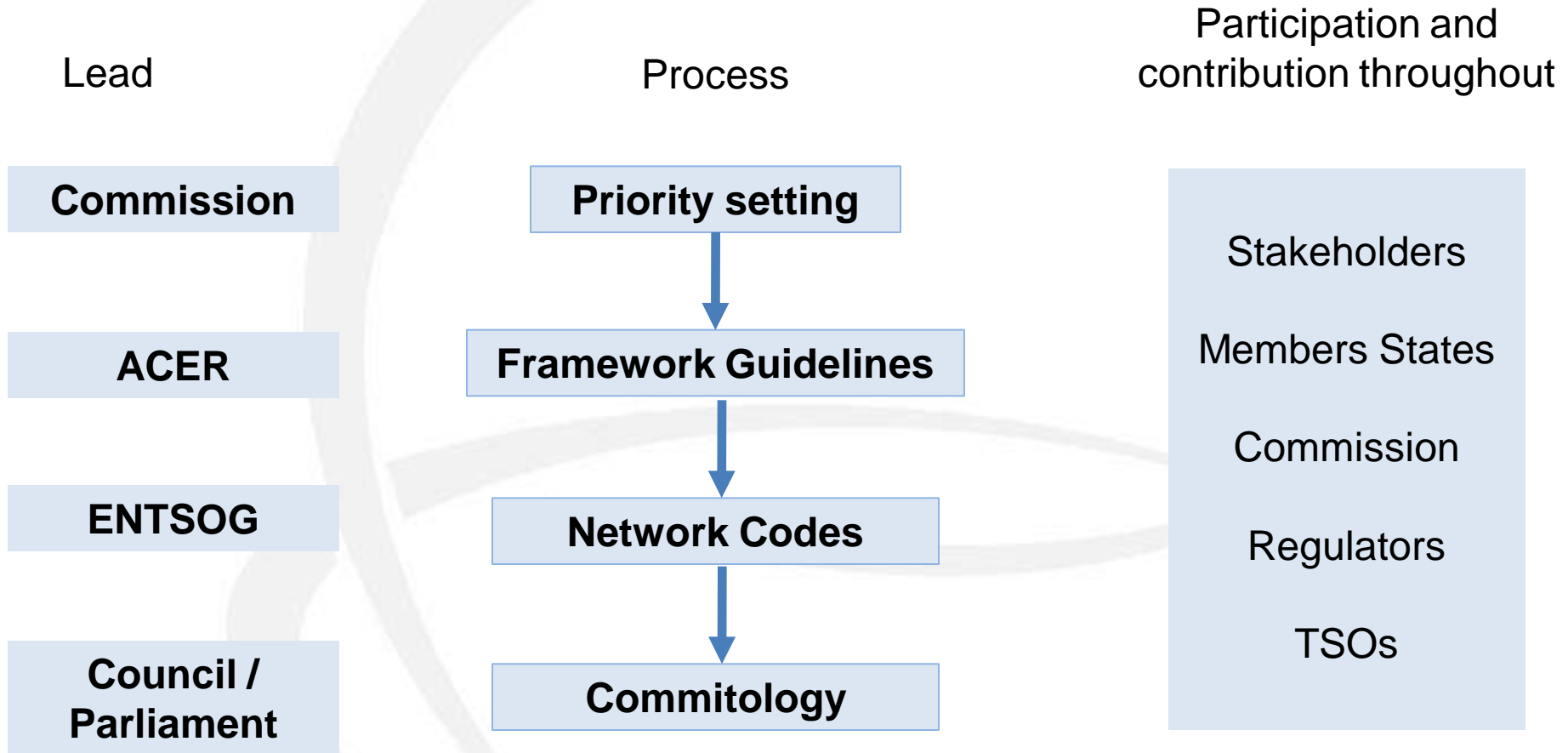

Network Code Development Timeline

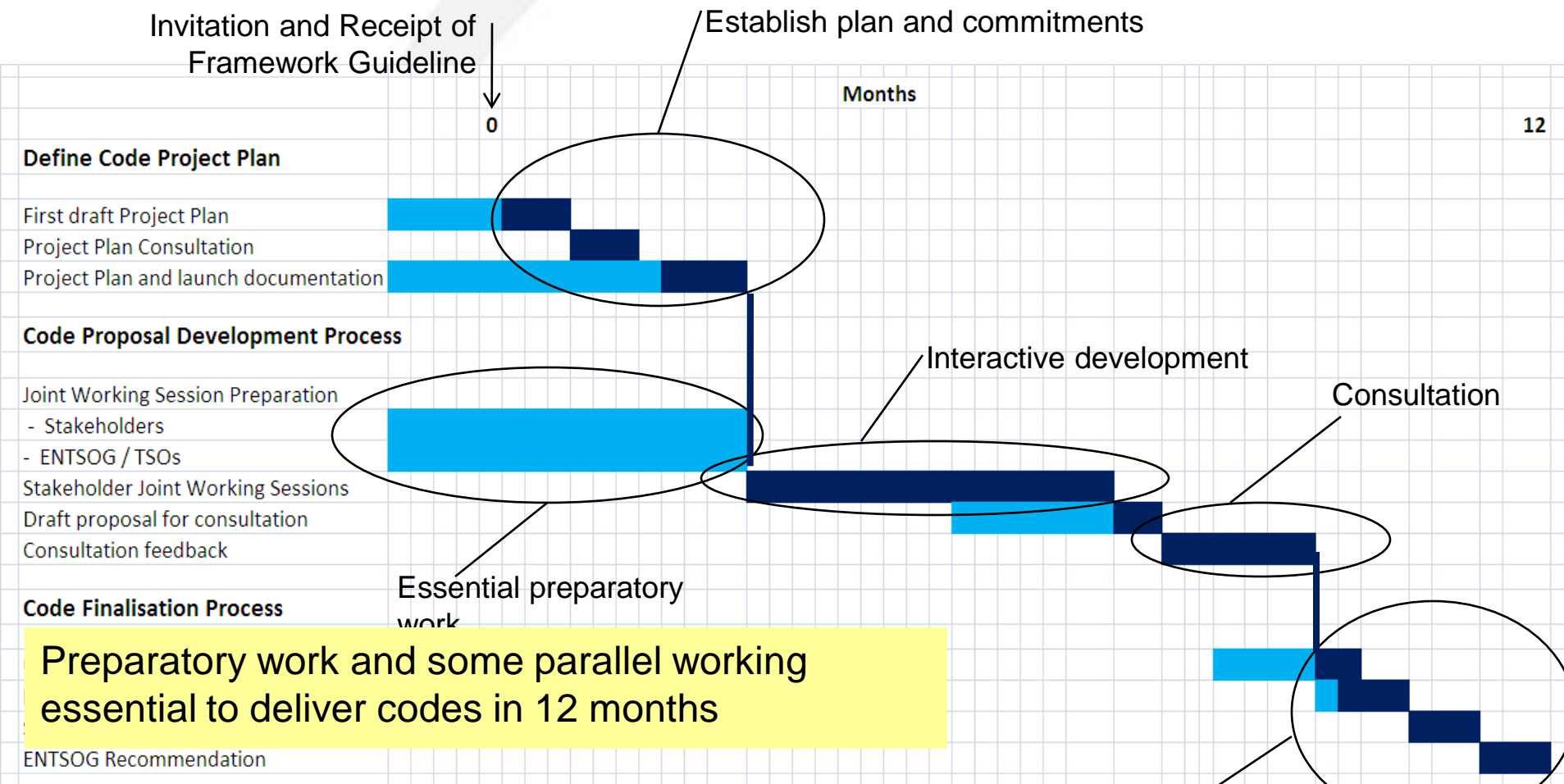

European Policies and Transmission systems – the future

Policy objectives:

- Sustainability
- Security
- Competition

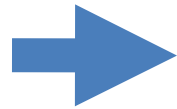

- Renewable generation
- Gas market integration



Gas implications

More local flexibility
More cross-border flexibility

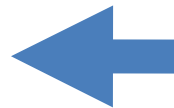

- More gas generation
- Increased cross-border gas flow

Infrastructure Package

European gas transmission network

- Various national objectives
- European sources of gas are changing
- Consumer market is evolving
- Greater capacity and improved network flexibility to achieve the Internal Gas Market

Definition of the objectives for the further development of the European gas transmission network needed

Planning and permitting

- **Streamline and accelerate national procedures**
 - **European priority infrastructure projects to be included within national planning**
 - **Local planning to concentrate on defining most suitable route without the “need case” to be justified**
- **Cross-border co-operation of regulators, permitting authorities and TSOs for European and regional projects**



Investment framework

European policy and regulators to provide sound infrastructure investment climate

ENTSOG committed to support the EU Commission in the further development of the Energy Infrastructure Package

Online information: www.entsog.eu

	Home	About Us	Publications	Maps & Data	Secure Area	Contact Us
Welcome	 <p>Welcome to entsog european network of transmission system operators for gas</p>					
<p>Welcome to ENTSG. European Gas TSOs working towards the delivery of the single European gas market.</p> <p>The European Network of Transmission System Operators for Gas (ENTSG) works to promote the completion and functioning of the internal market and cross-border trade for gas and to ensure the optimal management, coordinated operation and sound technical evolution of the European natural gas transmission network.</p>						

Conclusions

ENTSOOG started

TSOs ready and willing to work

Third Package requires commitment of all

- to make progress
- to contribute (participation & delivery)
- to work in a spirit of collaboration and compromise

Third Package processes must work efficiently

Co-operation of Commission, regulators, TSOs, Ministries
and all other stakeholders is essential